

# Manufacturing resource modelling



ROYAL INSTITUTE  
OF TECHNOLOGY

Mikael Hedlind

KTH Royal Institute of Technology  
Department of Production Engineering  
Stockholm, Sweden

# Manufacturing resource data management problem

Today development of manufacturing systems involves:

- Duplication of data in different application systems
- Interpretation of ambiguous and inconsistent data
- Difficulties to share and communicate data
- Time-consuming data collection and data re-creation
- Deficient verification and validation
- Expensive data archiving

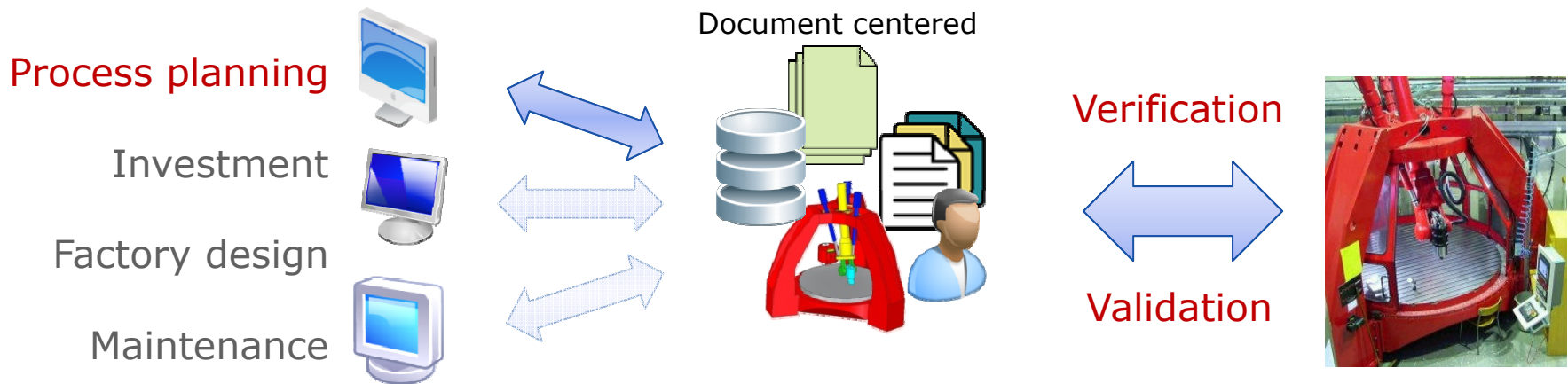

# Model incl. functional features and properties

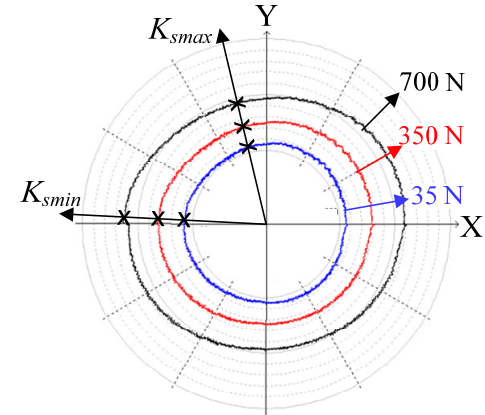
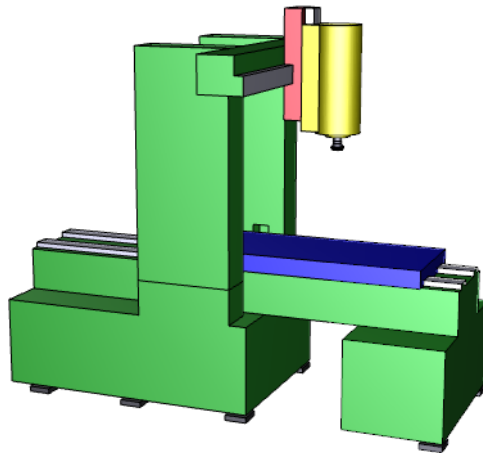

Circular motion path deflection  
(Loaded Double Ball Bar)

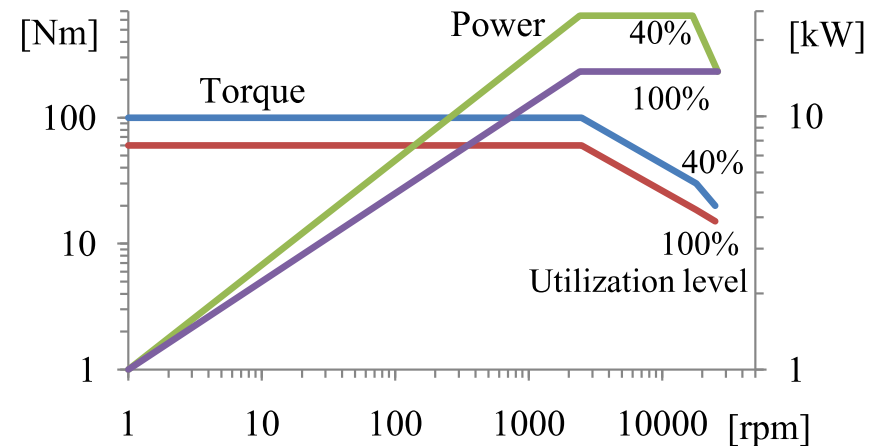
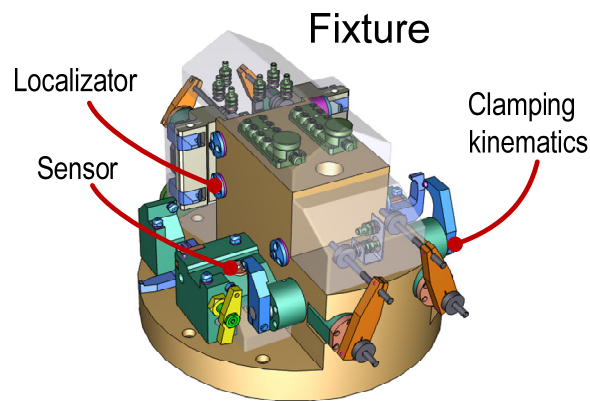

# Modelling method

- Stable and standardized data model also capable of representing resources developed in the future.
- Defined manufacturing resource concepts applied on a product generic information model.

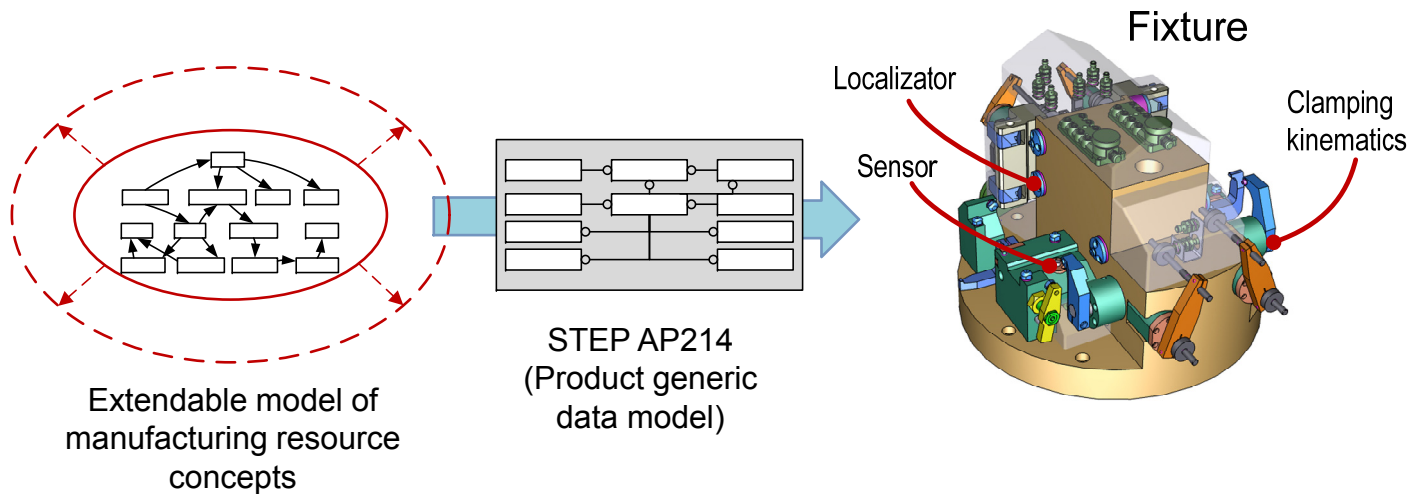

## AP214 for manufacturing resource data

- ISO 10303-214  
Generic standard for mechanical products  
(so far the only Application Protocol including kinematic representation)
- Manufacturing resource is one type of product

### Manufacturing resource information

- Functional
- Requirement
- Behaviour (thermal, damping etc.)

# ISO 10303-214

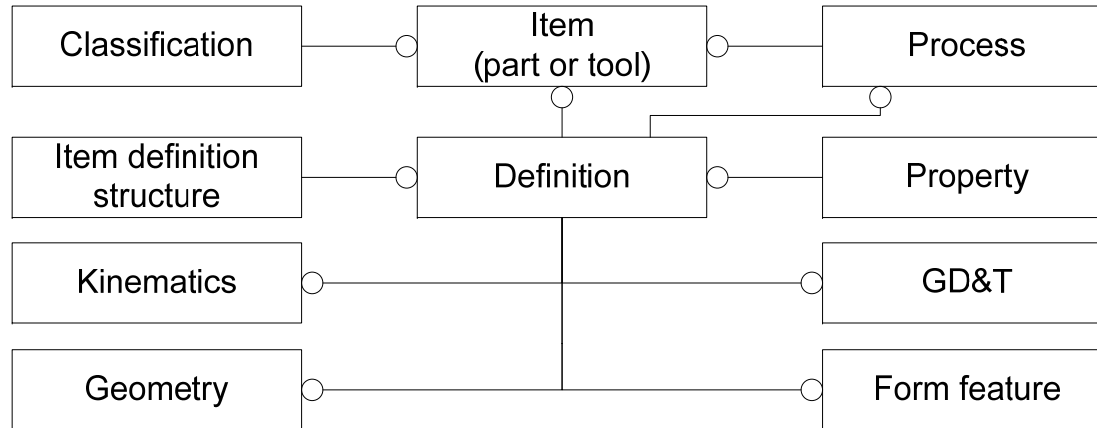

[Key excerpt of ISO 10303-214]

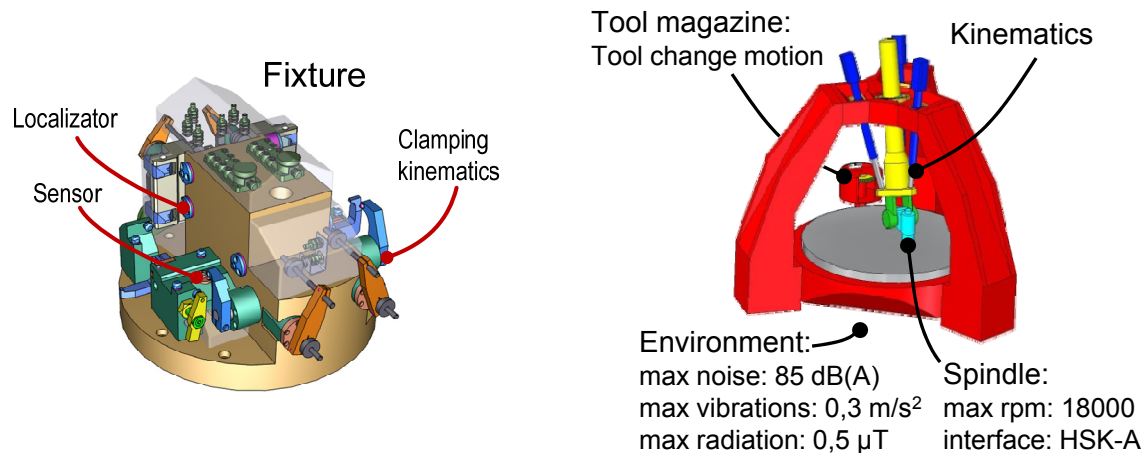

# Alias identification

- Allows use of different terminology in different contexts, applications and organisations

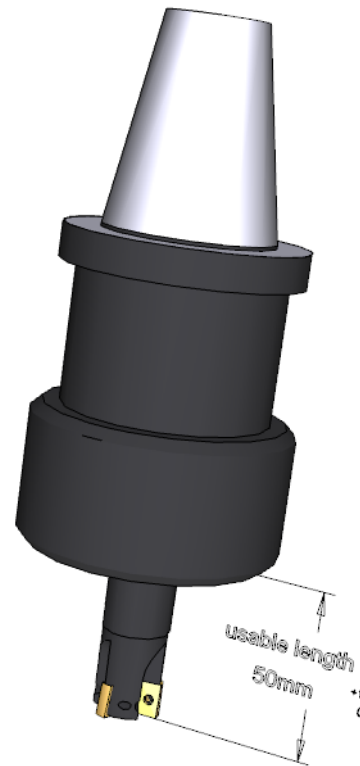

# AP214 property building blocks

<b>Property determination</b> <ul style="list-style-type: none"><li>• calculated</li><li>• <b>designed</b></li><li>• estimated</li><li>• measured</li><li>• required</li></ul>	<b>Value</b> <ul style="list-style-type: none"><li>• number</li><li>• string</li><li>• value list</li><li>• <b>value limit</b><ul style="list-style-type: none"><li>• maximum</li><li>• minimum</li></ul></li></ul>	<b>Unit</b> <ul style="list-style-type: none"><li>• <b>SI units</b></li><li>• derived units</li><li>• conversion units</li></ul>
<b>Properties relation</b> <ul style="list-style-type: none"><li>• decomposition</li><li>• <b>dependency</b></li><li>• hierarchy</li><li>• peer</li><li>• substitution</li></ul>	<b>Value relation</b> <ul style="list-style-type: none"><li>• decomposition</li><li>• <b>dependency</b></li><li>• equivalence</li><li>• substitution</li></ul>	<b>Identifier</b> <ul style="list-style-type: none"><li>• <b>name</b></li><li>• id</li><li>• version</li></ul>

Combined it can represent e.g.:

Designed maximum spindle motor torque in Nm unit is dependent on the spindle speed.



# Mechanical and CNC Kinematics

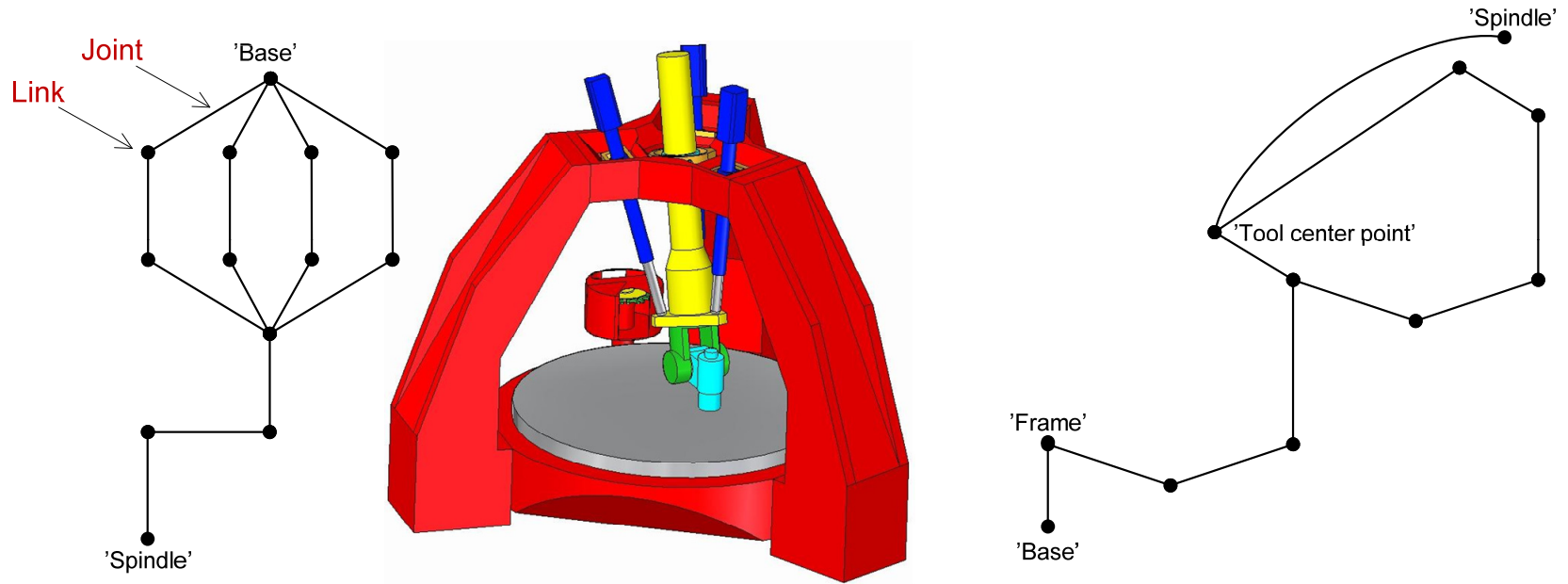

[STEP, ISO 10303-105]

# Kinematic pairs

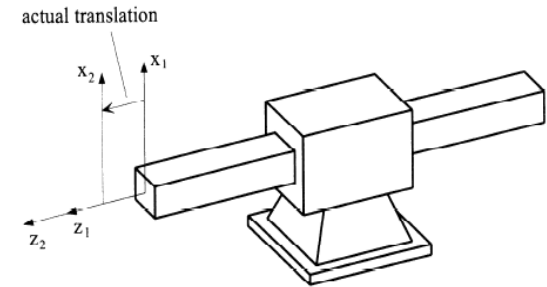

Example of a joint representing a prismatic pair  
[Fig. source: ISO 10303-105]

Low order pairs	High order pairs
revolute pair	point on surface pair
prismatic pair	sliding surface pair
screw pair	rolling surface pair
cylindrical pair	point on planar curve pair
spherical pair	sliding curve pair
universal pair	rolling curve pair
planar pair	planar curve pair
gear pair	surface pair
rack and pinion pair	
unconstrained pair	
fully constrained pair	
homokinetic pair	

# Kinematic pair

- Pair placement  
Placement of the pair frame in the context of the links.
- Pair range  
Specifies the allowable range of configurations of the two links that join a kinematic-pair. Lower end upper limit for each DOF.
- Pair value  
specifies the configuration of the two links that join a kinematic-pair.

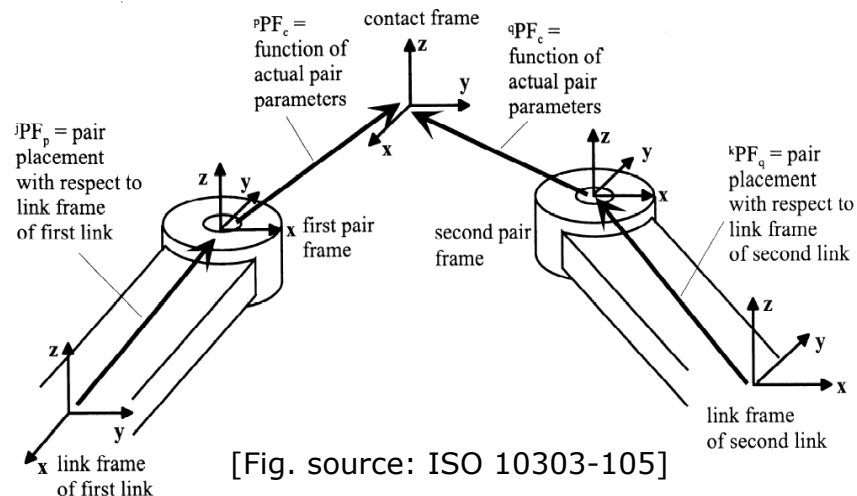

# Kinematic pair

- Actuator

Kinematic pair is either fully actuated (all degrees of freedom) or not at all.

- Hydraulic cylinder

Actuated translation (Z axis) with free rotation.

∴ Represent kinematics of a hydraulic cylinder with a actuated prismatic pair and a not actuated revolute pair in a closed kinematic chain.

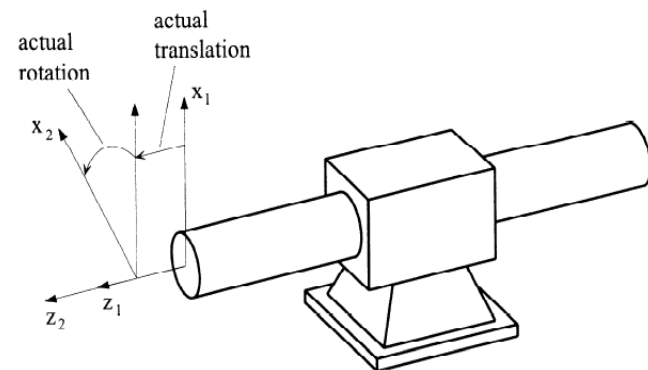

cylindrical pair

[Fig. source: ISO10303-105]

## AP214 Kinematic control and analysis result

- Representation and exchange of result information of a kinematic simulation.
  - Motion of a kinematic structure, defined by a set of configuration interpolations.
  - Motion parameter may be defined with time units.
- Can be used for describing tool changer motion.
  - Controlled by PLC program (e.g. IEC 61131-3) and/or maybe a source for PLC program generation...
- Corresponds to axis trajectory in STEP-NC.



# Kinematic topology representation of a wire-driven parallel mechanism (special type of Gough-Stewart platform)



[Picture source: [www.nist.gov](http://www.nist.gov)]

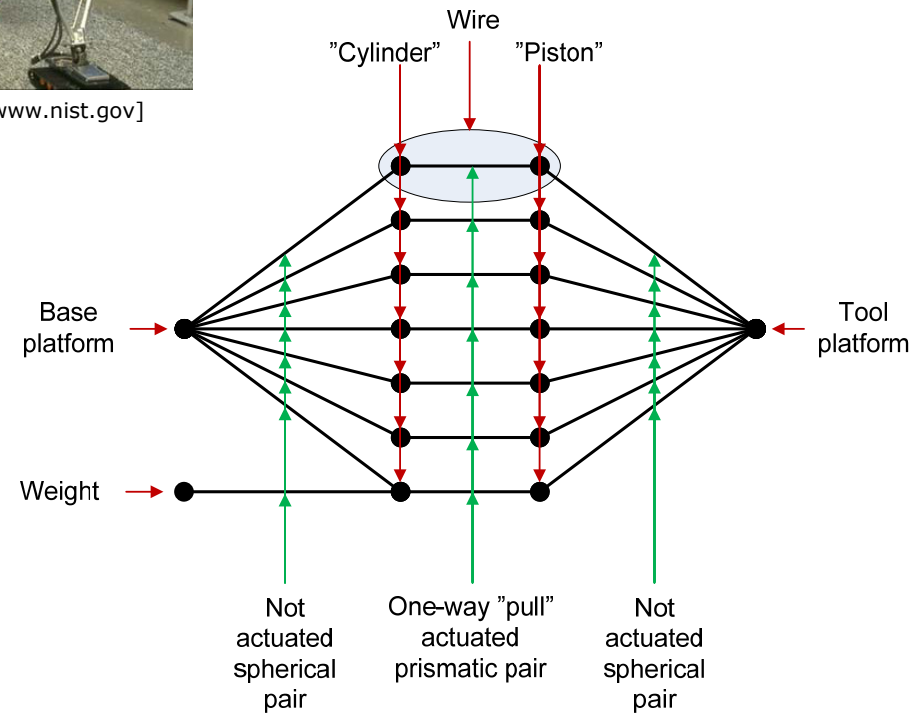
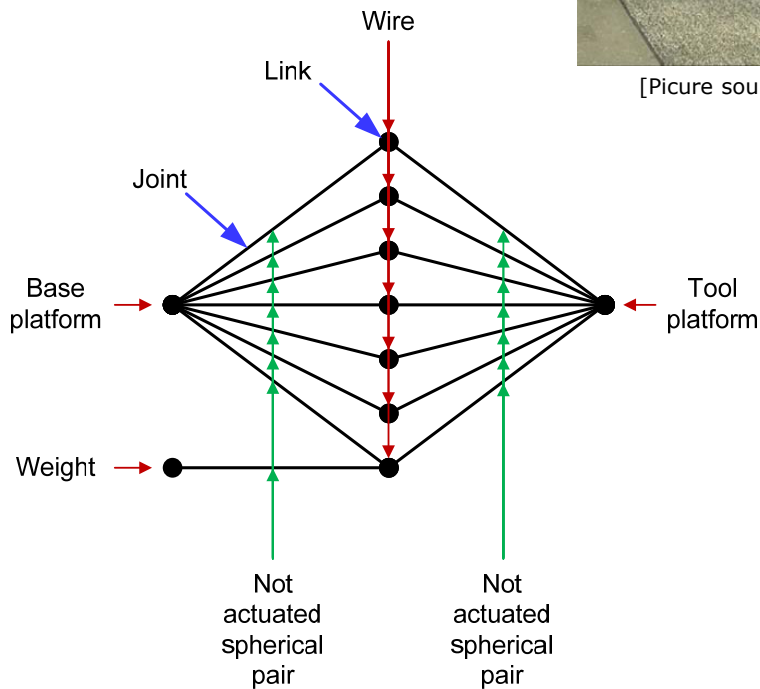

# ISO 10303 coherent models

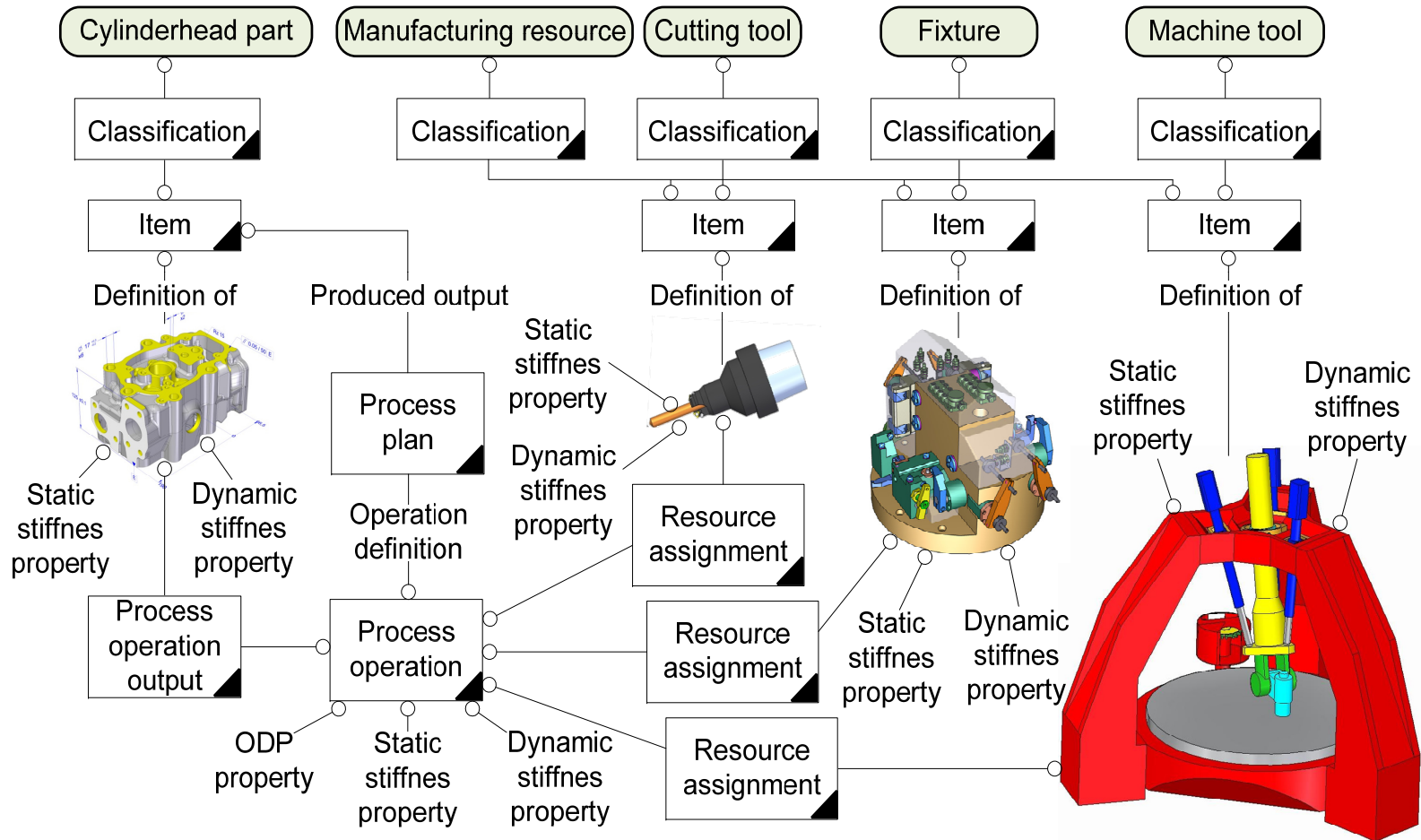



# Mapping specification

Data model with interface to externally defined concepts

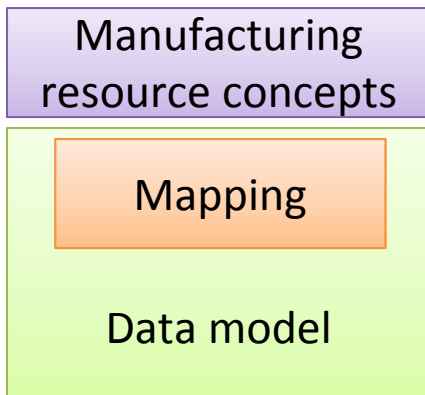

(e.g. PLCS and ISO 13399)

Modeling method where externally defined concept also can be used at all entity attributes

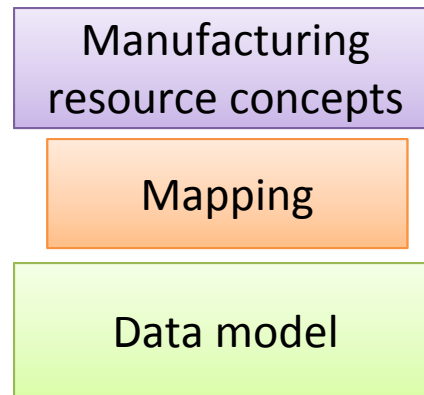

(e.g. ISO/CD 10303-5001)

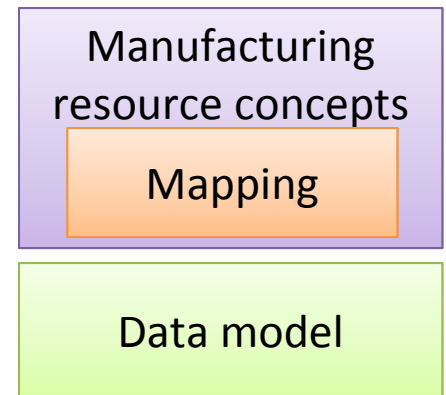

# Support for cross application work

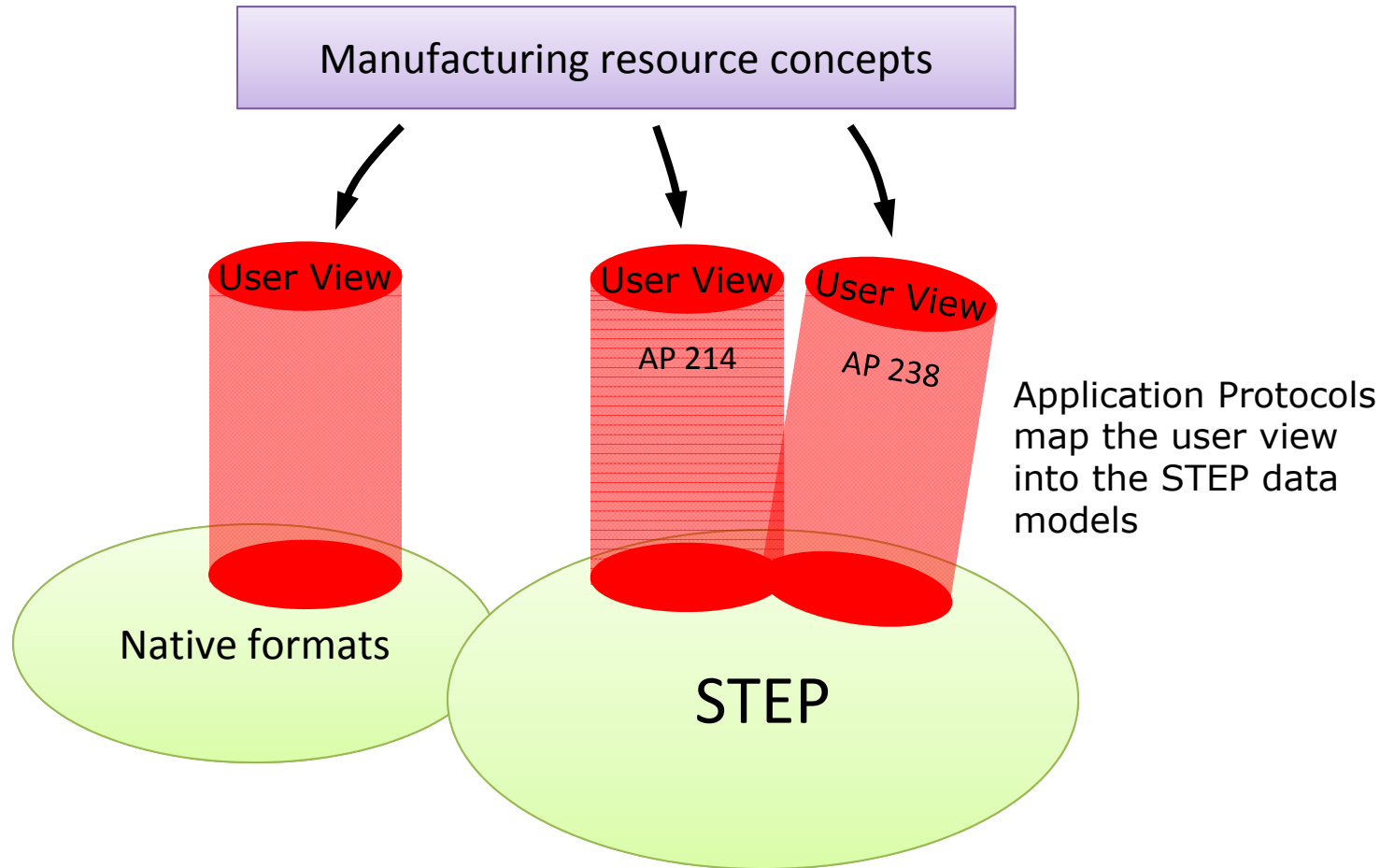

[Figure modified from original by Howard Mason, Chairman, ISO TC184 SC4.]

# Model based data management

- Stable and standardized information model also capable of representing future machine tool designs.
- Applying STEP to represent geometry, GD&T, kinematics, functional features and properties.
- Supports work in different domains, work interaction and application interoperability.

